

# Pumped Portable Molten Salt Loop

Fully autonomous operation with  
up to 600°C flowing molten salt

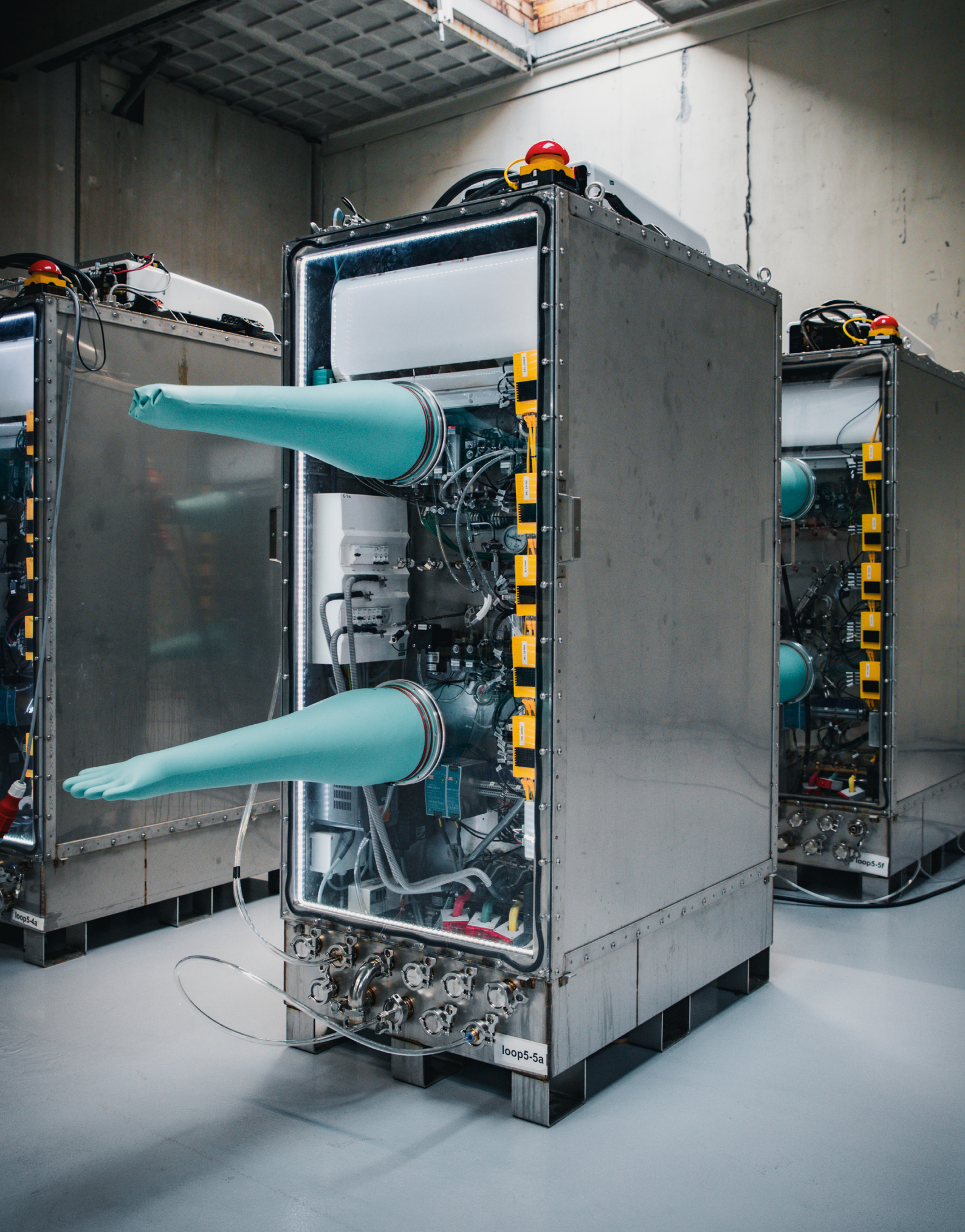

# Loop Version 5.6

## Highlights

The CA molten salt loop is versatile and can be adapted to multiple use-cases.

### Fully integrated test platform

Fully integrated molten salt test platform running up to 600 °C integrated with our proprietary automated operation, and alarm system and cloud based data logging system.



### High flow and temperature

Loop operation up to 600 °C and flow up to 300l/min. Fully contained inside the loop cabinet.

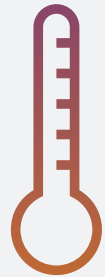

### Cloud data interface

Cloud data acquisition/ interface to process test data with other systems and data export feature.



### Delivered and tested by us

Delivered and tested with highly purified salt from Copenhagen Atomics.

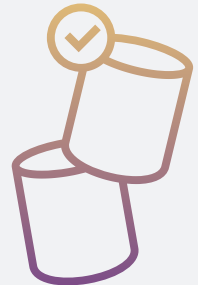

### Safe and modular

Comes with a double barrier safety concept, and Ability to swap components and to customize test loop.



### Rapid risk reduction

Accelerates time scales and reduces project risks on science experiments and a versatile foundation for any molten salt experiments.

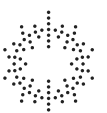

# The molten salt loop

## Introduction

---

Copenhagen Atomics' portable molten salt loop is designed as an accessible testing and development platform for researchers and engineers.

- ✓ The loop can be used to perform various experiments e.g. components testing such as tests of gaskets, flanges, filters, valves, pressure sensors, flow meters, heat exchangers, etc., at a wide range of flow conditions, temperatures, salt composition, etc.
- ✓ The loop is also well suited for material and chemistry experiments, e.g. salt material compatibility testing, graphite salt entrainment testing, corrosion testing, plate out, radiolysis etc.
- ✓ The ability to test materials, components and technologies at relevant dynamic conditions enables fast development and demonstrate the durability and feasibility required for approval. The loop is constructed in a modular fashion which enables the user to swap and connect different components.
- ✓ Each loop is constructed and tested with FLiNaK or other custom salts at the factory, by Copenhagen Atomics, before shipping.

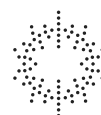

# The molten salt loop

The system streams all of the measurement data to a secure database in the cloud.

The measurements are accessible through our password protected web charts interface. From here all data can be downloaded to a local machine.

The system uploads more than 50 data points 10 times a second. These are values like temperatures, pressures, current, voltage etc.

## Sensors in the molten salt loops:

- Salt temperature
- Pumped salt pressure
- Salt flow detection
- Oxygen (1st and 2nd barrier)
- Humidity (1st and 2nd barrier)
- Pump RPM & current
- Gas flow rate
- Salt level
- Salt flow rate
- Salt leak detection

● STANDARD

● OPTIONAL

## The loop has two inert gas atmosphere containments.

The primary barrier contains the salt and the secondary barrier contains the furnace, gas systems, control hardware and spill tank.

The secondary containment ensures that even in the case of a leak of salt or vapour from the primary barrier, the environment outside the loop is not contaminated.

The primary and secondary barriers are made from 316 and 304 respectively, unless other materials are specified.

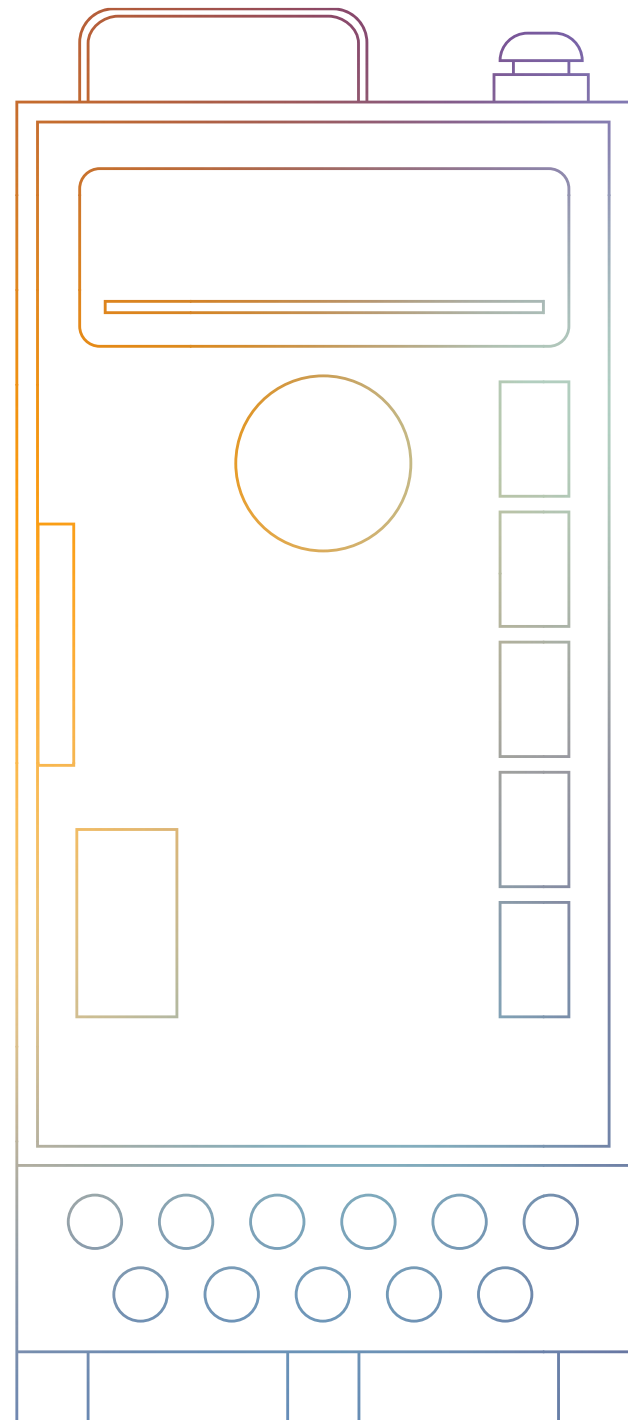

# Features

The molten salt loop is suitable for rapid prototype validation, long durability testing, salt compatibility testing, and many types of experiments that requires a molten salt flow.

Components such as gaskets, flanges, filters, valves, pumps, pressure sensors, flow meters, heat exchangers, etc. can be tested in a dynamic molten salt environment.

## Loop furnace

The internal volume of the loop's furnace is approximately 350 liters and have been tested up to 600° Celcius. Depending on the configuration, about half of this volume is available for customization to suit various experiments and test.

## A versatile test platform

The salt circulates from the salt tank via the pump and back, completing a loop. The piping is equipped with salt pressure sensors, flow indicator, bypass filtration, valves, and can be customized to house other equipment, such as sample chambers, salt heater, salt heat exchanges, etc.

The salt tank contains 25L of molten salt that can be FLiNaK or another fluoride or chloride salt.

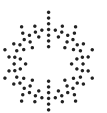
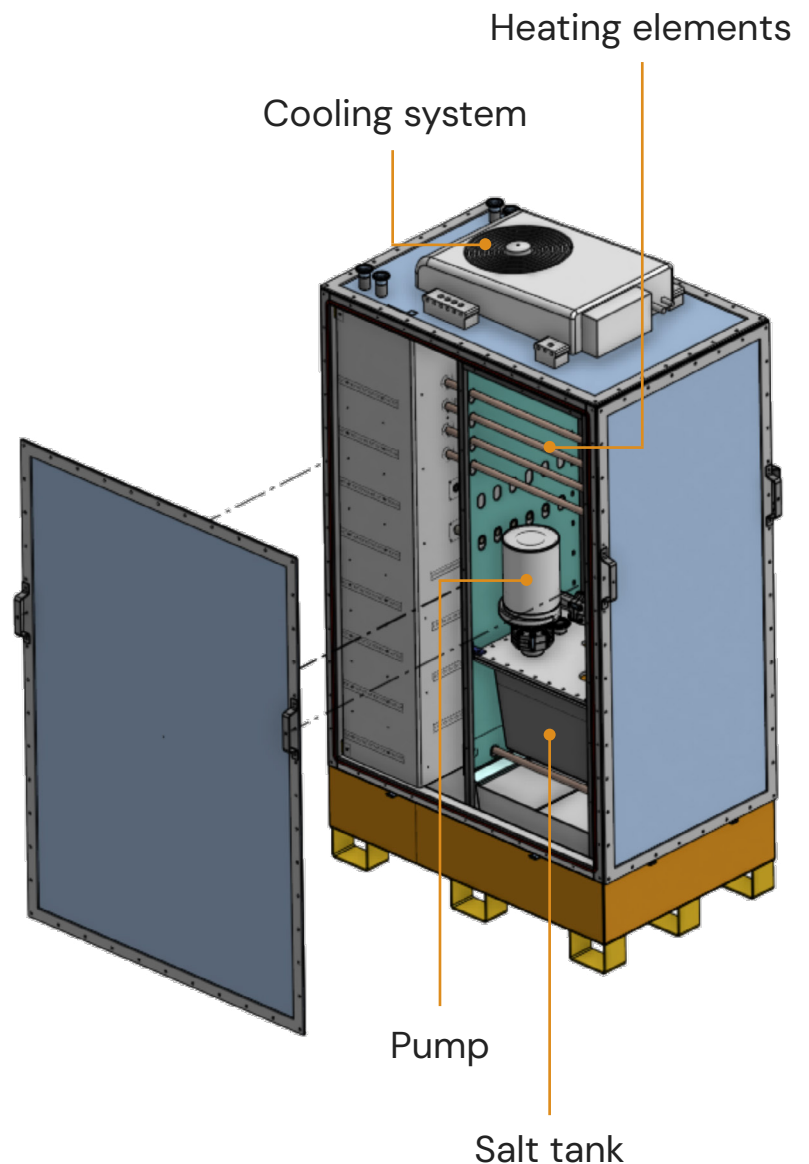

# Extensive software features available

Significant value in a Copenhagen Atomics pumped loop is the hardware and the high quality salt. The rest is the software and the data handling.

## WebUI

The test loop is operated by a mobile phone or a computer via a web interface. Ability to start, stop and run scripts, and to adjust temperatures and pump speed. Unique login with assigned privileges for each loop user.

This is also where you update software, firmware and scripts and change the naming of your sensors and set alarms.

## PlotsUI – real time web charts

This is how you view everything going on inside the loop, while it is running. You can view data recorded in real time from home or from your mobile phone. Zoom in on data and download data as .csv files (or Excel files).

With the Copenhagen Atomics plotsUI it is easy to set up individual views. And the user interface makes it easy to browse historical data.

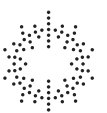

# Copenhagen Atomics

## Purified Salts

The loop can be operated with fluoride and chloride salts at temperatures up to 600 °C.

The loop is loaded and tested with pre-melted fluoride, chloride. With the most common being LiF-NaF-KF eutectics mixtures.

Copenhagen Atomics produces highly purified salts to eliminate corrosion challenges. Special salts are offered on request.



The standard loop contains 25 liters of fluoride, chloride, or similar molten salt, purified and premelted.



The modular nature of the CA molten salt loop allows for exchanging the salt and tank.



Connection to an external salt tank or extend with an additional furnace space on request.

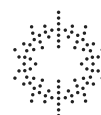

# Exterior piping features



We have proven solutions when it comes to pumping molten salt outside of the furnace and loop cabinet.

This allows for connection to external systems, such as a glovebox or experimental components.



# Dimensions

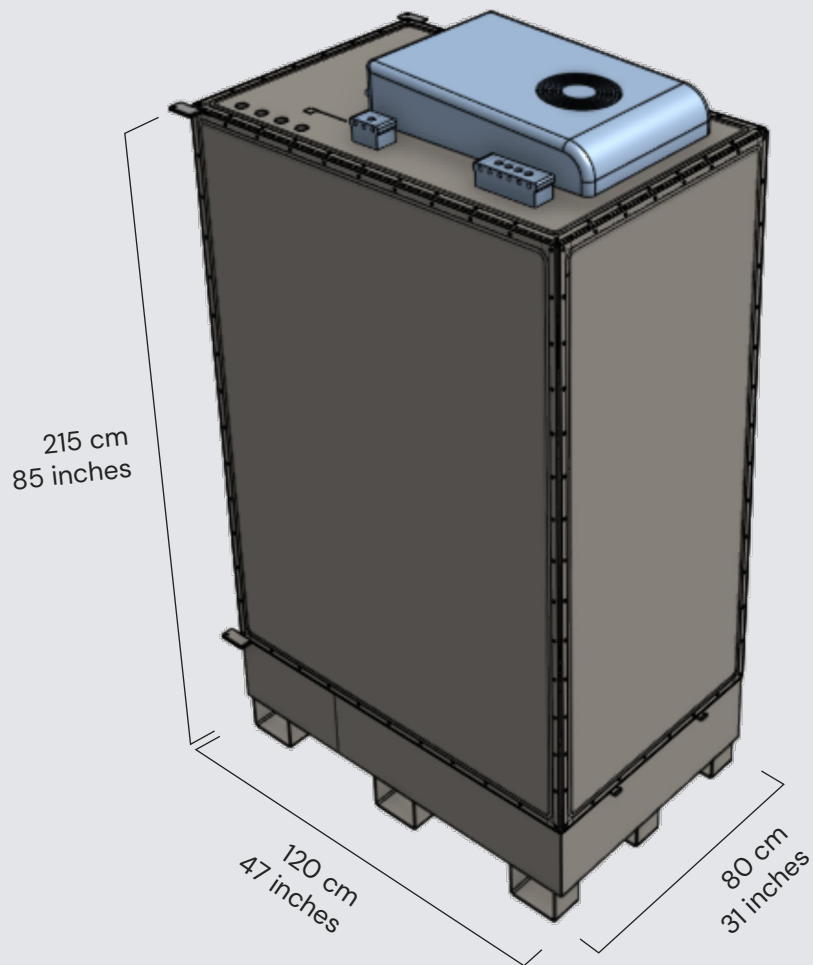

## Generic loop technical specifications

Max input power	22kW (32Amp – 3phase – 400Volt)
Max temperature	600°C
Max flow rate	300 liters per minute
Max salt load	Up to 32 liters
Cover gas	Argon (Pressure gas cylinders not included)
Typical initialization and heat-up time	5 days
Total loop weight	~900 kg (including salt)

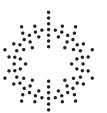

# Contact Copenhagen Atomics

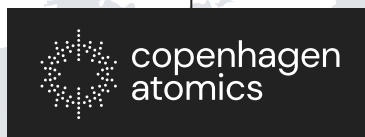

[sales@copenhagenatomics.com](mailto:sales@copenhagenatomics.com)  
[copenhagenatomics.com](http://copenhagenatomics.com)



Copenhagen Atomics A/S  
Oliefabriksvej 77  
2770 Kastrup  
Denmark

Copenhagen Atomics reserves the right to change or update information and values of this datasheet at any time without prior notice. Please inquire for the current version.

